



VELJAN

Service Information

SS4 - 00126

VT6CP

Single vane pump

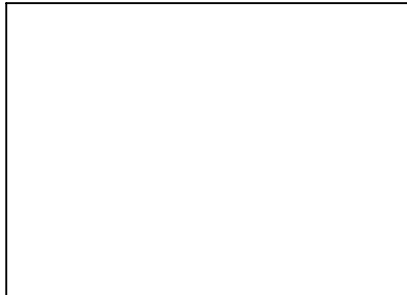

PHOTO

Bold printed are recommended repair kits and assemblies

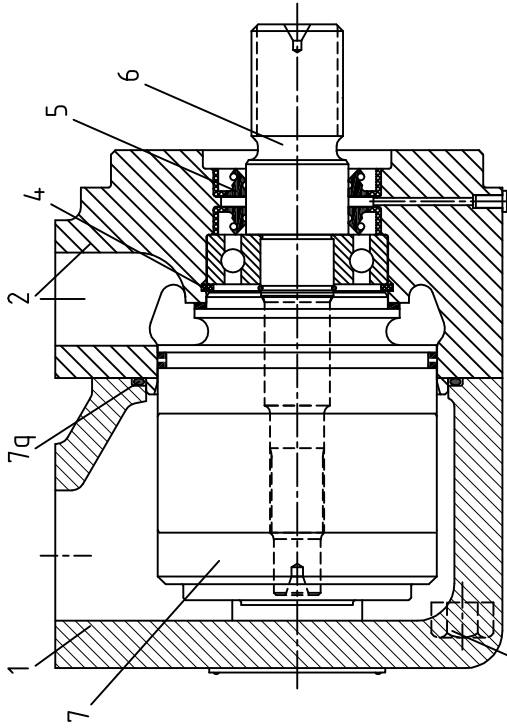

Mounting torque : 117 ft. lbs
(159 Nm)

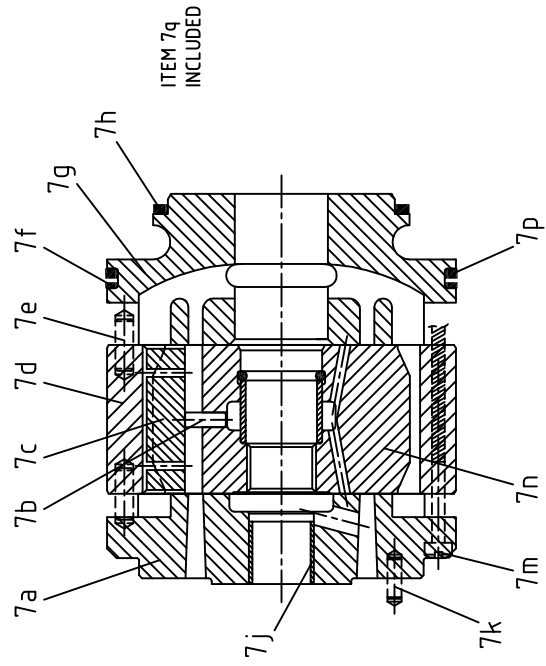
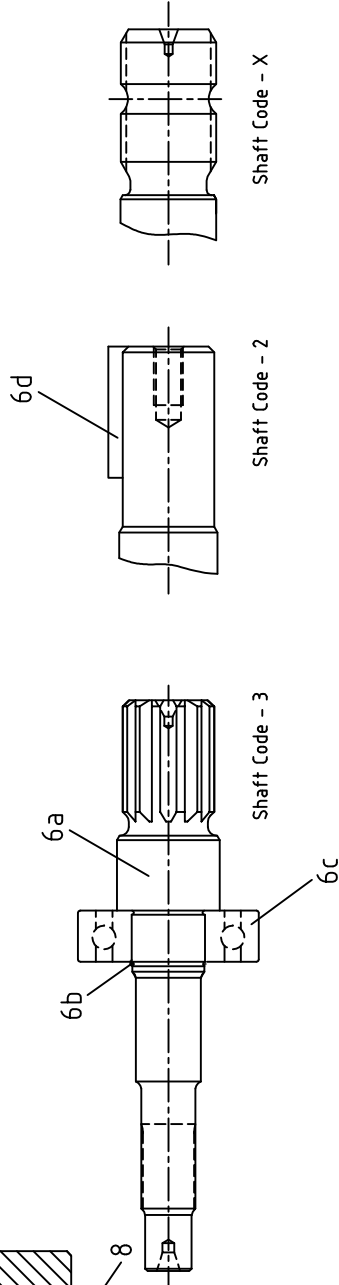

Item pos.	Description	Part No.	Qty
1	Housing Standard	H-034-66582	1
2	Mounting flange Standard	H-034-66583	1
3	Mounting Screw	V306-40038	4
4	Retaining ring	V356-30244	1
5	Shaft seal (S1-0.7 bar)	V620-82062	2
	Shaft seal (S4-S5-7 bar)	V620-82066	

6	Shaft and bearing ass'y (#2)	VS24-26646	1
	Shaft and bearing ass'y (#3)	VS24-26309	
	Shaft and bearing ass'y (#X)	C-S14-72208	
6a	Shaft (Keyed) (Code-2)	H-034-66606	1
	Shaft (Splined) (Code-3)	H-034-66584	
	Shaft (Splined) (Code-X)	C-034-03251	
6b	Round section ring	V034-70777	1
6c	Ball bearing	V230-82054	1
6d	Key (Code -2)	V034-49676	1
7	Cartridge assembly B14 CW	VS24-30109	1
	Cartridge assembly B14 CCW	VS24-30110	

Item pos.	Description	Part No.		Qty
		VT6CP		
	Cartridge assembly B15 CW	C-S14-72149		
	Cartridge assembly B15 CCW	C-S14-72150		
	Cartridge assembly B17 CW	VS24-30111		
	Cartridge assembly B17 CCW	VS24-30112		
	Cartridge assembly B20 CW	VS24-30113		
	Cartridge assembly B20 CCW	VS24-30114		
	Cartridge assembly B22 CW	VS24-30115		
	Cartridge assembly B22 CCW	VS24-30116		
	Cartridge assembly B25 CW	VS24-30117		
	Cartridge assembly B25 CCW	VS24-30118		
	Cartridge assembly B28 CW	VS24-30119		
	Cartridge assembly B28 CCW	VS24-30120		
	Cartridge assembly B31 CW	VS24-45791		
	Cartridge assembly B31 CCW	VS24-45792		
7a	Port plate - rear Bi-dir	V034-59047		1
7b	Pin vane holdout	V034-24982		10
7c	Vane	V034-66716		10
7d	Cam ring - 014	V034-59206		1
	Cam ring - 015	C-034-66893		
	Cam ring - 017	V034-59207		
	Cam ring - 020	V034-66607		
	Cam ring - 022	V034-59208		
	Cam ring - 025	V034-59209		
	Cam ring - 028	V034-59245		
	Cam ring - 031	V034-66843		
7e	Dowel pin	V324-21208		2
7f	Back-up ring	V618-15016		1
7g	Port plate - pressure Bi-dir	H-034-66453		1
7h	Sq. section seal	V691-10229		1
7j	Bush	V034-71867		1
7k	Dowel pin	V323-82010		1
7m	Screw	V317-06266		2
7n	Rotor-insert ass'y	VS24-30049		1
7p	Sq. section seal	V691-10238		1
7q	O' ring	V671-00244		1
8	Plug	V449-00501		1

Item pos.	Description	Part No.		Qty
		VT6CP		
5, 7f,	Seal kit (S1 - 0.7 bar)	VS24-26645		1
7h, 7p,	Seal kit (S4 - 7 bar)	VS24-26645-4		
7q,	Seal kit (S5 - 7 bar)	VS24-26645-5		
7a, 7j	Port plate - rear and bush assy	VS14-45605		1

MODEL CODE

VT6CP - *22 - 1 R 00 - A 1 *

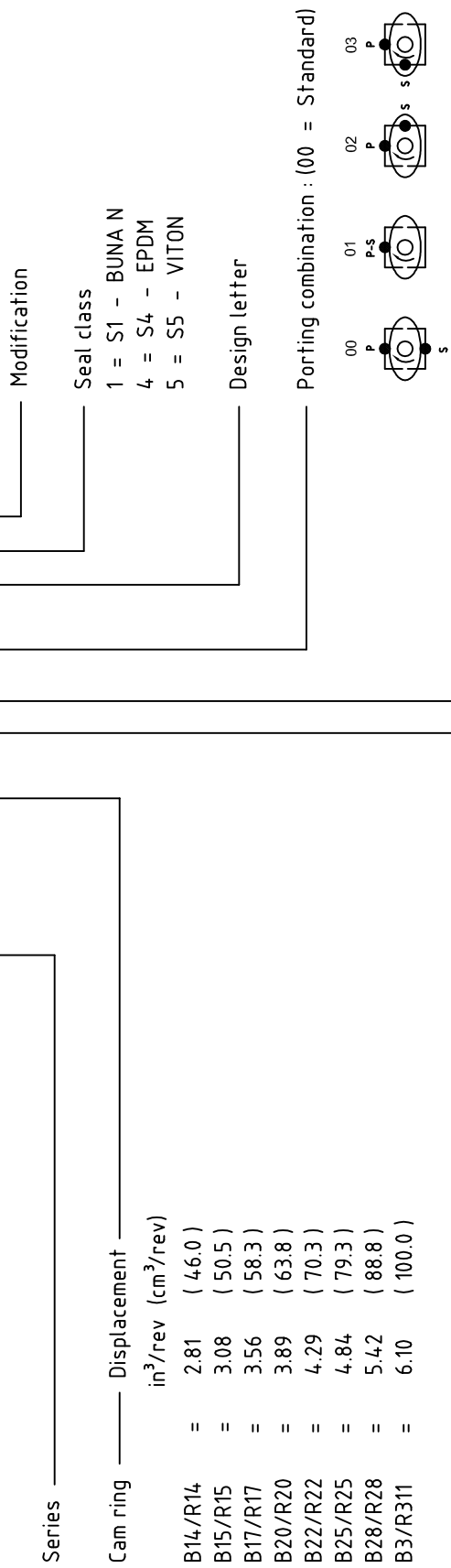

- Type of Shaft
- 2 = Keyed (no SAE)
 - 3 = Splined (SAE C)
 - X = Splined

To change porting position, follow the steps below:
 Secure pump and remove 4 bolts from housing. Move the housing 1 to 2 mm away from mounting flange. Insert Two bolt halfway to housing. Install a Wrench between the Two bolts and turn in the desired way, so that the required position of pressure port with respect to suction is obtained. Reinstall the bolts and tighten to corresponding torque.
 Instruction: Do not remove housing completely from the mounting flange but only just 1 to 2 mm to avoid the cartridge pin to move out from the housing-dowel pin hole. Make sure no piece of paint enters in to the gap to avoid leakage.
 If it is difficult to turn housing put some hydraulic oil to the pressure port to lubricate the pressure port seals.

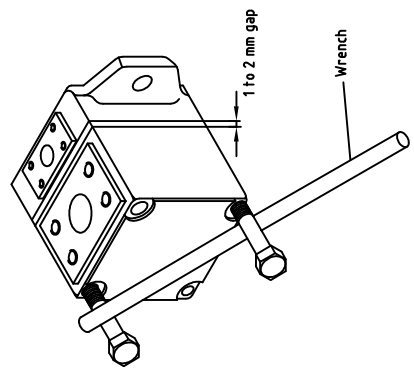

Veljan Hydrair Limited, Balanagar, Hyderabad - 500 037, INDIA. Phone: ++91 40 23772794, 95 FAX: ++91 40 23773963, E-mail: info@veljan.com

Print	_____
Replace	_____
Revision	_____

Printed in India

Rights of alteration reserved