

Temperature sensor for air TSA

RE 95181/10.2018

Replaced: 09.2018



- ▶ Typical use in fan controls
- ▶ Measuring range -30 °C ... 130 °C
- ▶ Resistor 800 ... 1550 Ohm temperature dependent
- ▶ Protection class IP64

Contents

Product description	2
Type code	3
Technical data	4
Dimensions	5
Accessories	6
Safety Instructions	7

Product description

The sensor element comprises a PTC nickel thin-film resistor, which is vapor-deposited onto a ceramic carrier substrate. This small plate is mounted in a plastic housing to protect it from damage. The lattice structure and hydrodynamic design of the inlet and outlet limit the sensor time constant and/or the delay.

Type code

Designation	Ordering No.
Sensor (without connector set)	0 538 009 203

The mating connector is not included in the scope of delivery.
This can be supplied by Bosch Rexroth on request (see Chapter
“Accessories”)

Technical data

Type	TSA	
Measuring range	-30 °C ... +130 °C	
Measurement accuracy	at 20 °C	±0.5 K
	at 100 °C	±1.1 K
Resistor	1000 Ω	
Tolerance	at 20 °C	±0.3 %
	at 100 °C	±0.5 %
Maximum permissible current	5 mA	
Time constant (in standing water)	→ 0	
Type of protection	IP 64 with the connector plugged in	
Plug connection	Jet connector, 2-pin	
Mounting type	2 x M6	
ROHS	EU-RoHS2-compliant	

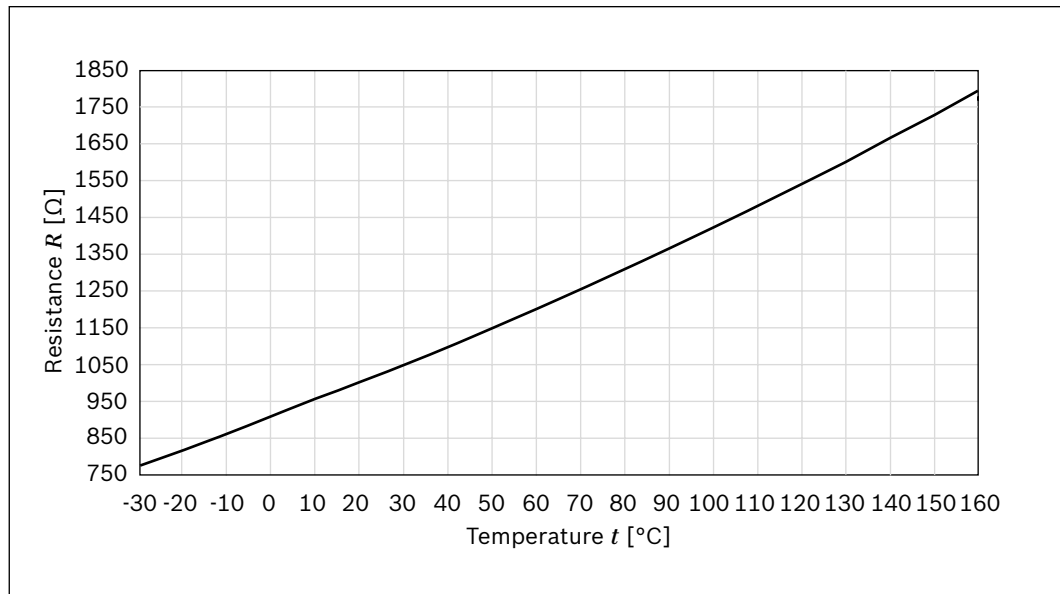

Temperature / resistance data

Temperature t	°C	-30	-25	-20	-15	-10	-5	0	5	10	15
Resistor R	Ω	775.2	796.3	817.7	839.5	861.5	883.8	906.4	929.4	952.6	976.2
Temperature t	°C	20	25	30	35	40	45	50	50	60	65
Resistor R	Ω	1000.0	1024.1	1048.6	1073.4	1098.4	1123.8	1149.4	1175.4	1201.7	1228.3
Temperature t	°C	70	75	80	85	90	95	100	105	110	115
Resistor R	Ω	1255.1	1282.3	1309.8	1337.6	1365.7	1394.1	1422.8	1451.8	1481.1	1510.7
Temperature t	°C	120	125	130	135	140	145	150	155	160	
Resistor R	Ω	1540.6	1570.8	1601.3	1632.2	1663.3	1694.7	1726.5	1758.5	1790.8	

Dimensions

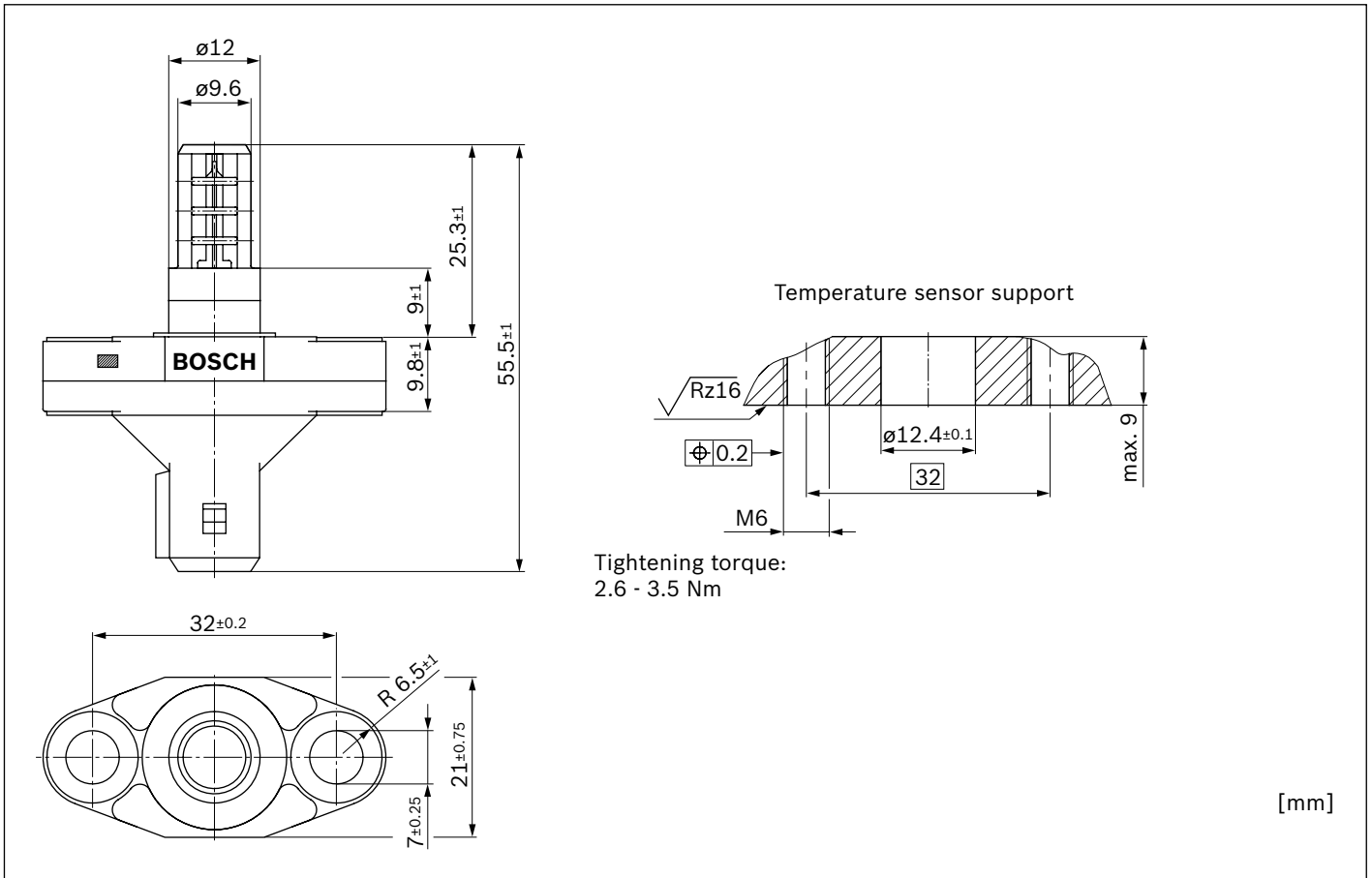

Accessories

Mating connector (connector set)

Material number	Connector set
R917000516	comprising: 1 x connector housing (Bosch-Material number 1284485110) 2 x contact spring (Bosch-Material number 1284477176, AMP- Material number: 925590-3) 1 x protective cap (Bosch-Material number 1280703026)

The mating connector is not included in the scope of delivery. This can be supplied by Bosch Rexroth on request.

Safety Instructions

General instructions

- ▶ Before finalizing your design, request a binding installation drawing.
- ▶ The proposed circuits do not imply any technical liability for the system on the part of Bosch Rexroth.
- ▶ Opening the sensor or carrying out modifications to or repairs on the sensor is prohibited. Modifications or repairs to the wiring could lead to dangerous malfunctions.
- ▶ The sensor may only be assembled/disassembled in a deenergized state.
- ▶ Only trained and experienced specialists who are adequately familiar with both the components used and the complete system should implement system developments or install and commission electronic systems for controlling hydraulic drives.
- ▶ When commissioning the sensor, the machine may pose unforeseen hazards. Before commissioning the system, you must therefore ensure that the vehicle and the hydraulic system are in a safe condition.
- ▶ Make sure that nobody is in the machine's danger zone.
- ▶ Do not use defective components or components not in proper working order. If the sensor should fail or demonstrate faulty operation, it must be replaced.
- ▶ Despite every care being taken when compiling this document, it is not possible to consider all feasible applications. If instructions for your specific application are missing, you can contact Bosch Rexroth.
- ▶ Sensors do not fall under the scope of EMC Directive 2014/30/EC. A declaration of conformity and the CE marking for individually sold sensors is not required, since these are passive sensors.
- ▶ The use of sensors by private users is not permitted, since these users do not typically have the required level of expertise.

Notes on the installation location and position

- ▶ Do not install the sensor close to parts that generate considerable heat (e.g. exhaust).
- ▶ Lines are to be routed with sufficient distance from hot or moving vehicle parts.
- ▶ A sufficient distance to radio systems must be maintained.
- ▶ Before electric welding and painting operations, the sensor must be disconnected from the power supply and the sensor connector must be removed.
- ▶ Cables/wires must be sealed individually to prevent water from entering the sensor.

Notes on transport and storage

- ▶ Please examine the sensor for any damage which may have occurred during transport. If there are obvious signs of damage, please inform the transport company and Bosch Rexroth immediately.
- ▶ If it is dropped, the sensor must not be used any longer, as invisible damage could have a negative impact on reliability.

Notes on wiring and circuitry

- ▶ Lines to the sensors must be designed so that they are as short as possible and shielded. The shielding must be connected to the electronics on one side or to the machine or vehicle ground via a low-resistance connection.
- ▶ The sensor mating connector must only be plugged and unplugged when it is in a deenergized state.
- ▶ The sensor lines are sensitive to spurious interference. For this reason, the following measures should be taken when operating the sensor:
 - Sensor lines should be attached as far away as possible from large electric machines.
 - If the signal requirements are satisfied, it is possible to extend the sensor cable.

- ▶ Lines from the sensor to the electronics must not be routed close to other power-conducting lines in the machine or vehicle.
- ▶ The wiring harness should be fixated mechanically in the area in which the sensor is installed (spacing < 150 mm). The wiring harness should be secured so that in-phase excitation with the sensor occurs (e.g. at the sensor mounting point).

Intended use

- ▶ The sensor is designed for use in mobile working machines provided no limitations/restrictions are made to certain application areas in this data sheet.
- ▶ Operation of the sensor must generally occur within the operating ranges specified and approved in this data sheet, particularly with regard to voltage, temperature, vibration, shock and other described environmental influences.

Improper use

- ▶ Any use of the sensor other than that described in the chapter "Intended use" is considered to be improper.
- ▶ Use in explosive areas is not permitted.

Use in safety-related functions

- ▶ The customer is responsible for performing a risk analysis of the mobile working machine and determining the possible safety-related functions.

Further information

- ▶ Further information about the sensor can be found at www.boschrexroth.com/mobile-electronics.
- ▶ The sensor must be disposed of in accordance with the national regulations of the country in which it is used.

- ▶ If possible, lines should be routed in the vehicle interior. If the lines are routed outside the vehicle, make sure that they are securely fixed.
- ▶ Lines must not be kinked or twisted, must not rub against edges and must not be routed through sharp-edged ducts without protection.

- ▶ Use outside of the specified and approved boundary conditions may result in danger to life and/or cause damage to components which could result in sequential damage to the mobile working machine.
- ▶ Serious personal injury and/or damage to property may occur in case of non-compliance with the appropriate regulations.

- ▶ Damages which result from improper use and/or from unauthorized, unintended interventions in the device not described in this data sheet render all warranty and liability claims with respect to the manufacturer void.

- ▶ In safety-related applications, the customer is responsible for taking proper measures to ensure safety (sensor redundancy, plausibility check, emergency switch, etc.).

Bosch Rexroth AG

Robert-Bosch-Straße 2
71701 Schwieberdingen
Germany
Service Tel. +49 9352 40 50 60
info.bodas@boschrexroth.de
www.boschrexroth.com

© Bosch Rexroth AG 2018. All rights reserved, also regarding any disposal, exploitation, reproduction, editing, distribution, as well as in the event of applications for industrial property rights.
The data specified above only serve to describe the product. No statements concerning a certain condition or suitability for a certain application can be derived from our information. The information given does not release the user from the obligation of own judgment and verification. It must be remembered that our products are subject to a natural process of wear and aging.